

No. 618,133.

Patented Jan. 24, 1899.

P. R. ROBERTS.
COMBINATION TOOL.

(Application filed Feb. 9, 1898.)

(No Model.)

3 Sheets—Sheet I.

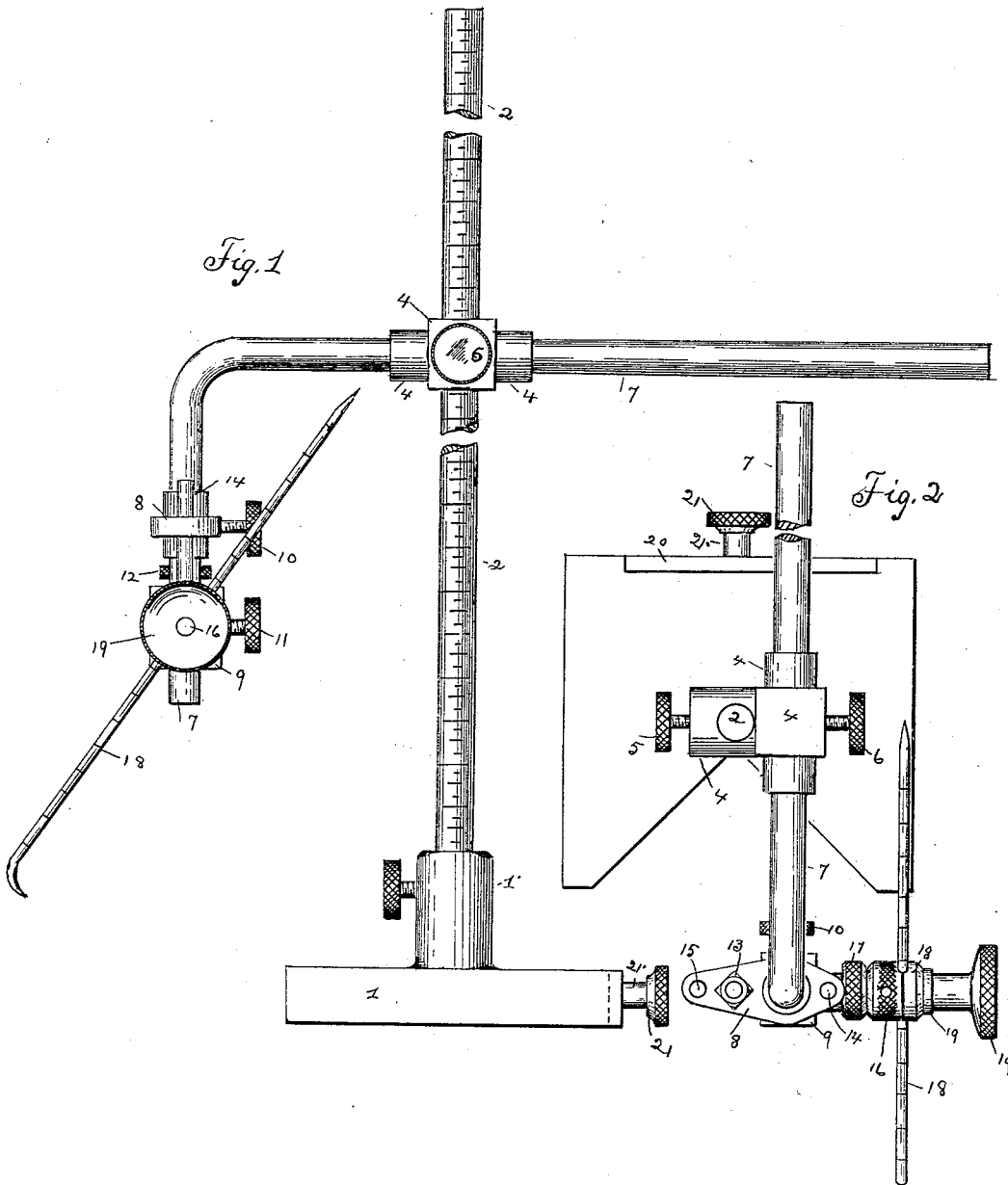

*Wm. H. & Co. 333 S. 3rd St.
 St. Louis
 M. Hunter*

Fig. 3

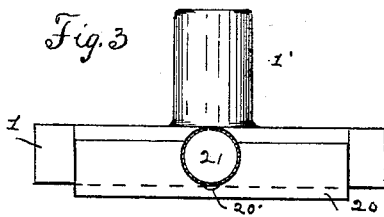

*Inventor
 Peter R. Roberts
 Per O. L. Lewis
 J. F. S.*

No. 618,133.

Patented Jan. 24, 1899.

P. R. ROBERTS.
COMBINATION TOOL.

(Application filed Feb. 9, 1898.)

(No Model.)

3 Sheets—Sheet 2.

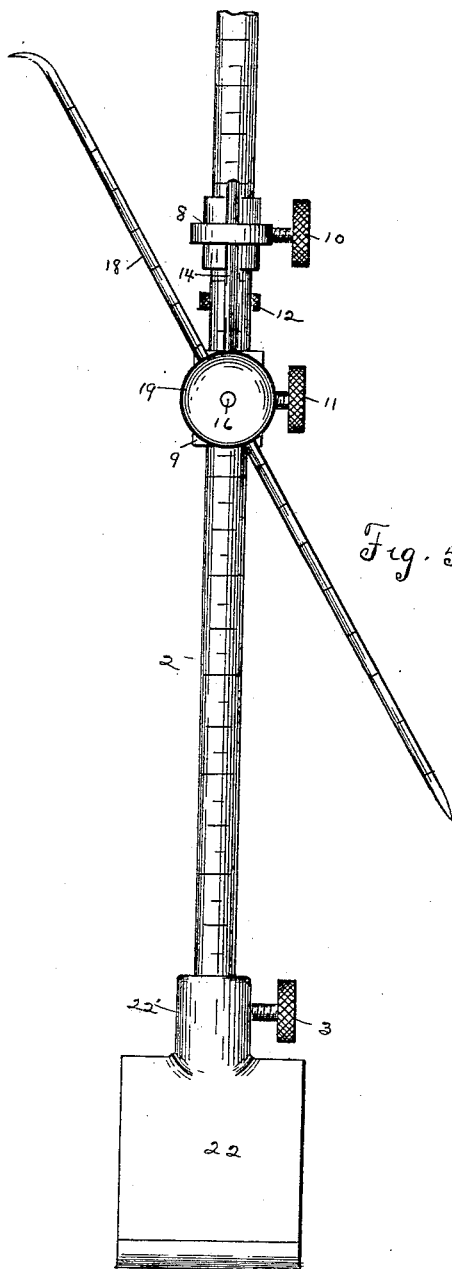
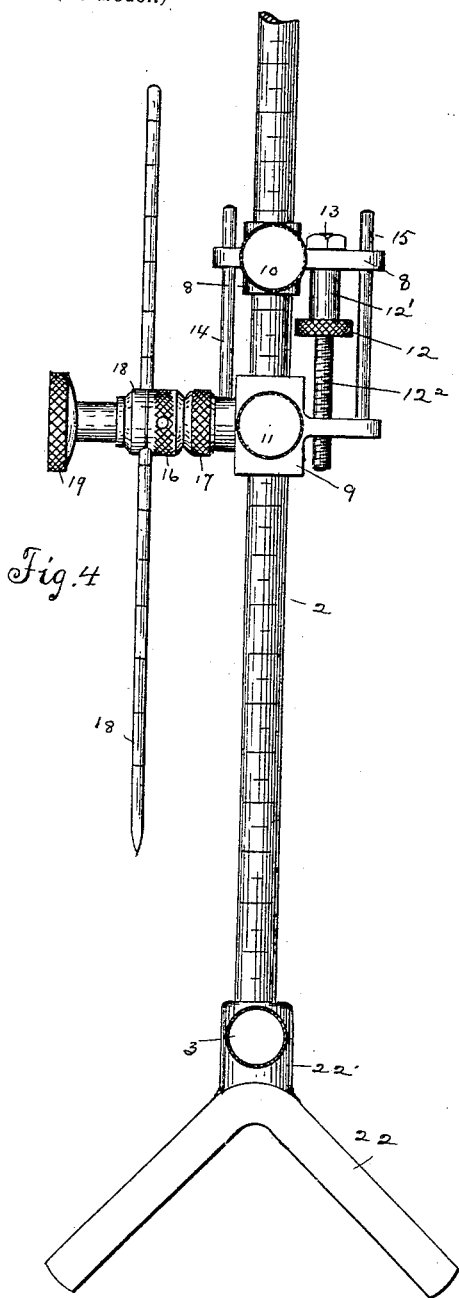

W. & S. S. & S.
H. Levin
M. Hunter

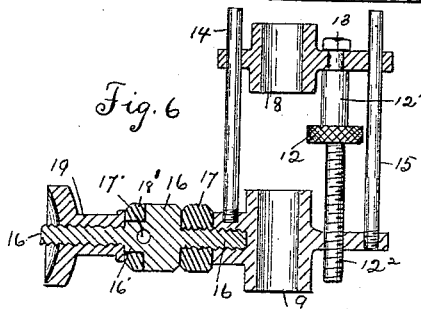

Inventor
Peter R. Roberts
By
O. D. Lewis
A. S. S.

P. R. ROBERTS.
COMBINATION TOOL.

(Application filed Feb. 9, 1898.)

(No Model.)

3 Sheets—Sheet 3.

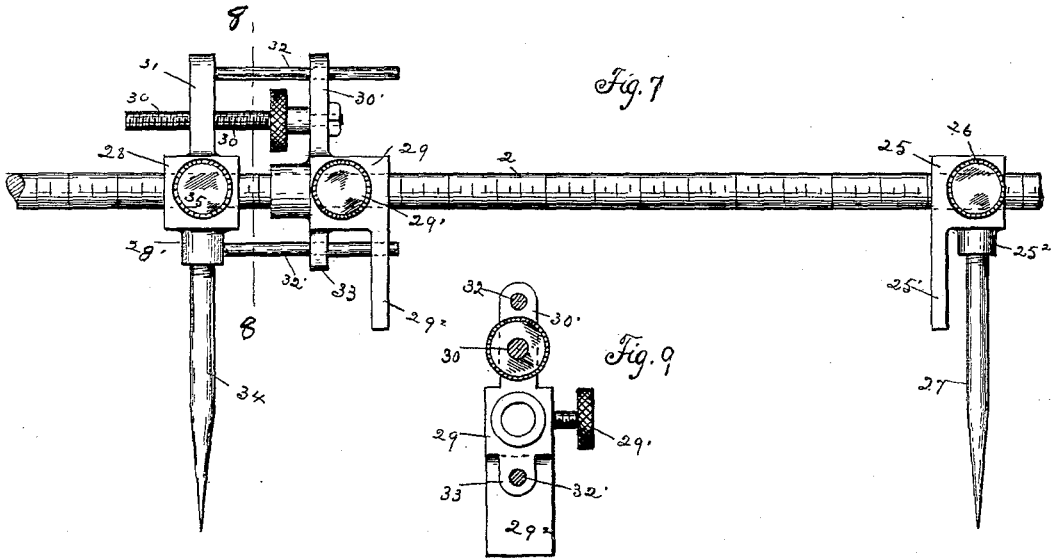

Fig. 7

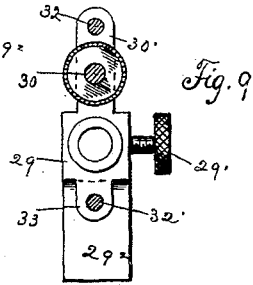

Fig. 9

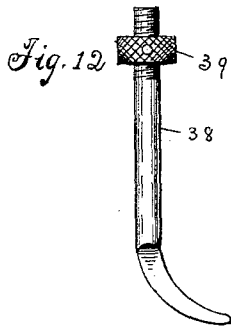

Fig. 12

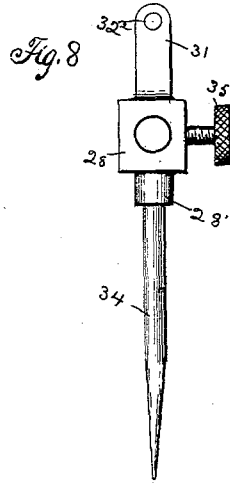

Fig. 8

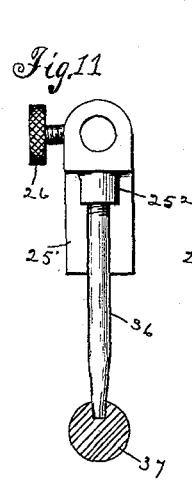

Fig. 11

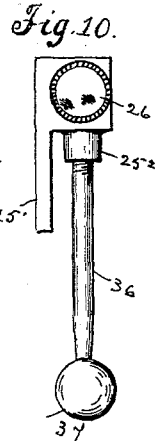

Fig. 10

Witnesses:
J. Lewis
M. Hunter

Inventor
Peter R. Roberts
Per O. Lewis
Witness

UNITED STATES PATENT OFFICE.

PETER R. ROBERTS, OF PITTSBURG, PENNSYLVANIA.

COMBINATION-TOOL.

SPECIFICATION forming part of Letters Patent No. 618,133, dated January 24, 1899.

Application filed February 9, 1898. Serial No. 669,646. (No model.)

To all whom it may concern:

Be it known that I, PETER R. ROBERTS, a citizen of the United States of America, residing at Pittsburg, in the county of Allegheny and State of Pennsylvania, have invented certain new and useful Improvements in Combination-Tools, of which the following is a specification, reference being had therein to the accompanying drawings.

This invention relates to certain new and useful improvements in a combination-tool for machinists' use.

The invention has for its object the provision of a tool for the use of machinists and in which the parts entering into its construction may be used separately or in conjunction with one another for the purpose of other tools, and by this means the machinist is enabled to equip himself with a number of tools which may be packed within a small space and at a considerable reduction of cost.

With the above object in view the invention finally consists in the novel construction, combination, and arrangements of parts, as will be hereinafter more specifically described in detail.

In describing the invention in detail reference is had to the accompanying drawings, forming a part of this specification and wherein like numerals of reference designate like parts throughout the several views, in which—

Figure 1 is a vertical side view of a surface-gage formed from a combination of various tools. Fig. 2 is a top plan view of the same. Fig. 3 is a side view of the base-piece of the same. Fig. 4 is a vertical side view of a boring-bar gage formed from a combination of some of the tools. Fig. 5 is a vertical front view of the same. Fig. 6 is a sectional view through the adjusting-blocks of the same. Fig. 7 is a side view of a pair of combined trammel-points, calipers, and micrometer-gage. Fig. 8 is a vertical face view of the adjustable trammel-point block in section upon the line 8 8 of Fig. 7. Fig. 9 is a vertical face view of the adjustable portion of the same block upon the line X X of Fig. 6. Fig. 10 is a vertical side view of the opposite trammel-block with a ball-center attached. Fig. 11 is a vertical face view of the same with the ball shown in section. Fig. 12 is a view of one of the caliper trammel-legs.

Referring to the drawings for the details of the surface-gage, the numeral 1 designates a metal base-piece having the vertical boss 1' 55 formed thereon. This base-piece has an opening formed down through it for the reception of the vertical rod 2, which is circular in cross-section, graduated in fractional parts of the inch, and is held in position to the base by 60 the thumb-screw 3. An adjustable block 4 is loosely fitted upon the vertical rod and is held in the desired position by the set-screw 5. This block has an opening formed through 65 it at right angles to that one where it fits upon the vertical rod and is provided with the thumb-screw 6. Loosely fitted into this opening of the block is the horizontal rod 7, which is circular in cross-section and turned over 70 at right angles at one end and is held in the desired position at the block by the aforesaid screw 6. Loosely fitted upon this turned-over portion of the rod are the blocks 8 and 9, having the thumb-screws 10 and 11 in connection therewith for securing them in place. 75 These blocks are adjustable in relation to one another by the screw 12. This screw is loosely connected to the upper block 8 by the shouldered portion 12' and nut 13, and the lower threaded portion 12² engages within a thread- 80 ed or tapped hole formed within the lower block, and in order to insure the blocks being moved parallel with one another when adjusted I employ the two pins 14 and 15, which 85 are securely attached to the lower block and loosely enter openings formed within the upper block. (See Fig. 6.) A double-ended screw 16, having the jam-nut 17 at one end, is screwed into a hole tapped within the lower 90 block. At the shouldered portion 16' of this screw is formed the hole 17' for the reception of the scriber 18. This scriber is held fast in the desired position by the sleeve 18' and nut 19 and can be set to any angle by means of the aforesaid jam-nut 17. A recess is formed 95 within one edge of the base-piece, and into this recess is loosely fitted the guide-plate 20. A thumb-screw 21, having the shouldered portion 21' formed thereon, is tapped into the base and enters through an oblong slot 20' in 100 the guide-plate, so as to allow the plate to be set down below the under surface of the base, as in Fig. 3.

If the device is to be used upon a planer or

lathe bed to scribe a line upon the piece of work, adjust the block 4 to raise or lower the horizontal rod 7, adjust this rod 7 to the desired position, adjust scriber so that point 5 will reach the surface upon which the line is to be scribed, and should the point of the scriber not come exactly to the point it may be adjusted by releasing screw 11 upon lower block 9, then turn screw 12 until point of 10 scriber is exactly at the point desired, then tighten up screw 11 and move gage along bed-plate. If it is desired to use the edge of bed-plate or a groove within the bed-plate as a straight-edge, the guide-plate 20 is set down 15 into this groove or over the edge of the bed-plate, as shown at Fig. 3. The vertical rod 2 may be of any length desired.

In Figs. 4 and 5 the device is shown arranged for use upon a boring-bar, and when 20 used in this form the right-angular base-piece 22 is used in place of the flat base. This right-angular base-piece is provided with a boss 22', through which is formed an opening for the vertical rod 2, and is held by screw 25 3. The horizontal rod 7 is dispensed with. The blocks 8 and 9 are removed, with their attachments, and arranged upon the vertical rod 2. In laying out work upon a lathe or boring-mill with this tool the right-angular 30 base-piece is set upon the boring-bar, the blocks and scriber are then adjusted to reach the work, as described, in the surface-gage. The device is then moved around the boring-bar, or the boring-bar is turned and the tool 35 is held in place.

Referring to Fig. 7, a pair of combined trammels and calipers is shown, in which the numeral 2 is the graduated rod of the surface-gage, and upon this rod is mounted the block 40 25. This block has the downwardly-extended flange 25' and the boss 25² formed upon it and is held to the rod by thumb-screw 26. The boss portion of this block has a threaded opening formed within it for the reception of the 45 point 27. The other trammel-point consists of the two parts 28 and 29, the part 29 being held upon the rod by the thumb-screw 29', and is provided with a downwardly-extended flange 29², similar to the other tram- 50 block. An adjustment-screw 30 is loosely attached to the upwardly-extended lug 30', which is formed upon this block, and the threaded end of this screw extends over through a threaded opening formed within the upwardly-extended lug 31 of the other block 55 28. A pair of parallel rods 32 and 32', which form guides for the adjusting of the blocks from or toward one another, are attached to the block 28, one being attached to the afore- 60 said lug 31, extending across, and enters loosely within an opening 32² at the top of the lug 30' of the opposite block. The other guide-rod 32' is attached to the boss 28' of the block 28 and extends across through an opening 65 formed within the lower lug 33 and flange 29² at the under side of the block 29. A point

34 is screwed into a threaded opening within the boss 28'. In using this as a trammel the blocks are moved so as to bring the points as near the diameter desired as possible, and to 70 get the points exact the screw 35 of the block 28 is released, and by turning screw 30 the point may be adjusted either in or out, as desired, after which the aforesaid screw 30 is again tightened up. In calipering the diam- 75 eter of an outside ring the inner faces of the flanges 25' and 29' are used. The outer surfaces of these flanges may also be used for calipering other work. If the trammels are used upon a piece of work where it is desired 80 to scribe a line from the center of an opening, the point 27 is removed from the block and the point 36 substituted. This point has the ball 37 fitted upon its lower end and is of such diameter as to rest easily upon the edges of 85 the opening from which the center is taken, thus acting as a bearing.

Both points may be removed from the tram- blocks and a pair of caliper-legs, such as the one shown at Fig. 11 and designated as 38, 90 substituted. These legs are provided with jam-nuts 39, so that the legs may be held securely in place either when used as inside or outside calipers. They may also be made of various lengths to suit. 95

A number of other tools may be formed by either using some parts separately or combin- ing them together.

Having thus shown and described my invention, what I claim as new, and desire to 100 secure by Letters Patent, is—

1. In a combination-tool, the combination with the rod, the adjustable block 8 thereon, the rods passing therethrough, the adjustable 105 block 9, to which said rods are secured, the rotatable screw connected with block 8 and engaging with a screw-threaded recess in block 9, the double screw engaging with a recess in block 9, but formed with a hole for the passage of a tool, the sleeve and the jam- 110 nut, substantially as described.

2. The combination with the base, the vertically-adjustable graduated rod, the slide- block adjustably mounted thereon, having a horizontal hole, and the adjustable horizontal 115 bar having its ends bent downwardly at a right angle, of the upper adjustable block on the bent end of the horizontal rod, the pins passing therethrough, the lower adjustable block to which said pins are secured, the ad- 120 justing-screw connecting said blocks, the double screw connected with the lower block and formed with a hole for the passage of a scriber, the collar and the jam-nut, substantially as described. 125

In testimony whereof I have hereunto set my hand.

PETER R. ROBERTS.

Witnesses:

JOHN GROETZINGER,
J. J. HACKETT.